

# Forge Bicycles Quick Assembly Guide

For reference only. Please refer to Owner's Manual for complete assembly instructions.

1

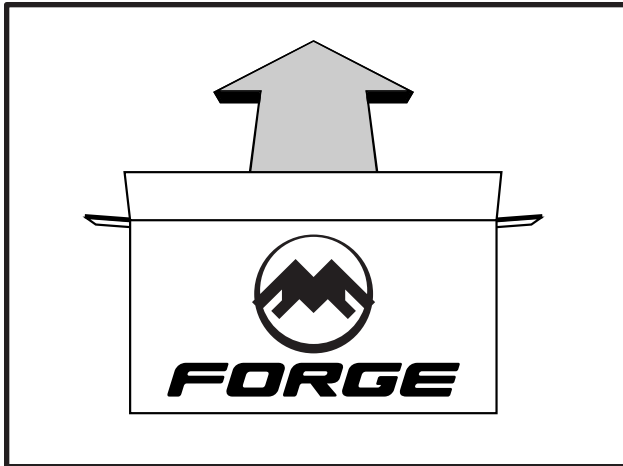

Unpack everything from the shipping box.

2

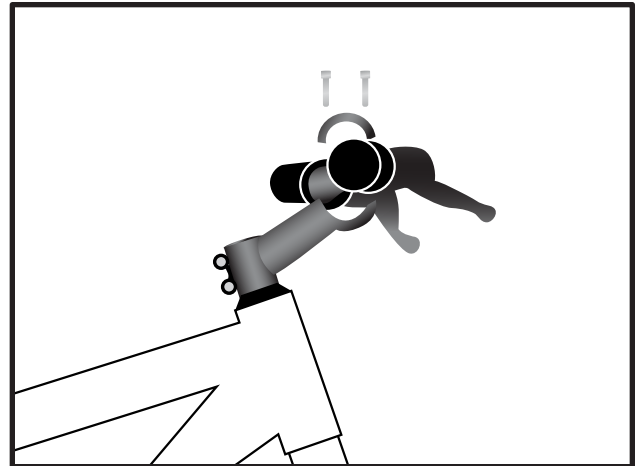

Attach handlebars to stem. Adjust to fit and then tighten, being careful not to tangle the cables.

*\*If you have a Vero or Athena Model see Page 2 for stem installation.*

3

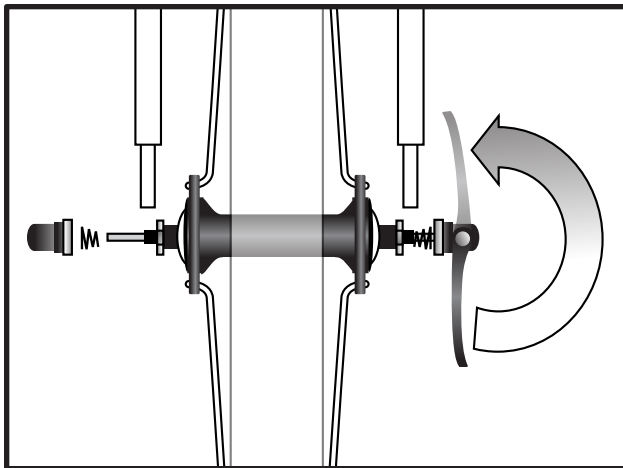

Insert quick-release skewer into front wheel as shown (illustration is facing front of bike) and attach front wheel to bike. Tighten skewer by hand until snug and then flip lever to closed position.

*\*If your model is equipped with disc brakes see Page 2 for installation instructions BEFORE you attach the wheel.*

4

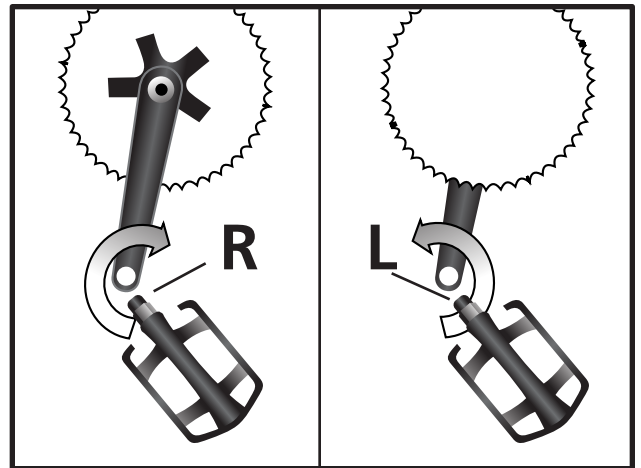

Attach right pedal (pedals marked "R" and "L" on spindle) with a 15mm wrench, turning **CLOCKWISE**. Attach left pedal in same manner, but turning wrench **COUNTER-CLOCKWISE**.

5



Insert seatpost past minimum insertion mark and adjust seat height to fit. Tighten quick-release until snug and then flip lever to closed position.

6



Check to make sure brakes and derailleurs are functioning properly. Ensure all bolts have been properly tightened and tires are inflated to their recommended pressure (indicated on sidewalls). **GO RIDE!**